

ALL WORK SHALL BE ACCOMPLISHED IN ACCORDANCE WITH THE LATEST EDITION OF THE WSDOT STANDARD SPECIFICATIONS FOR ROAD, BRIDGE, AND MUNICIPAL CONSTRUCTION

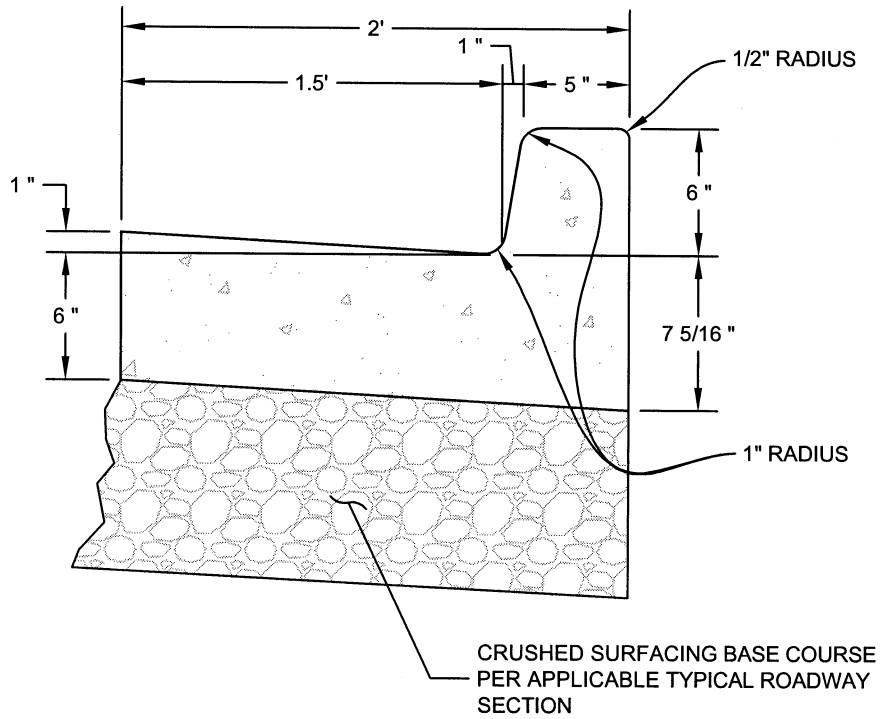

**SECTION VIEW**

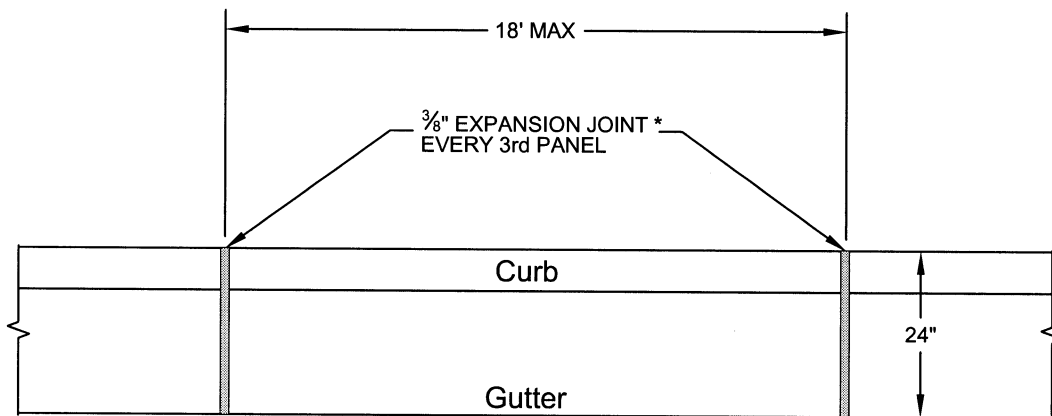

Match joint spacing of adjacent pavement, or multiples of joint spacing of adjacent sidewalk.

\* Expansion joints shall be pre-molded, and conform to WSDOT Spec. 9-04.1

**PLAN VIEW**

RGL  
DESIGNED BY  
JMC 3/6/07  
DRAWN BY  
KAC  
APPROVED BY  
3-21-07  
DATE

**CONCRETE CURB & GUTTER**

TYPICAL APPLICATIONS  
N T S



DEPARTMENT OF PUBLIC WORKS  
207 4th AV. NORTH  
KELSO, WASHINGTON  
98626

DRAWING:CC-1201

SHEET  
1  
OF  
1